

Graphic Symbol

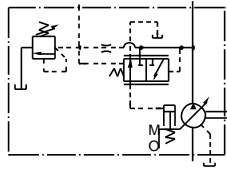

Performance Characteristics

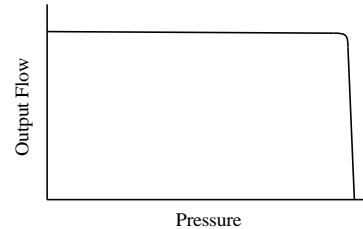

Specifications

Model Numbers	Geometric Displacement cm ³ /rev (cu. in. /rev)	Minimum Adj. Flow cm ³ /rev (cu. in. /rev)	Operating Pres. MPa (PSI)		Minimum Adj. Pres. MPa (PSI)	Shaft Speed Range r/min		Approx. Mass kg (lbs.)	
			Rated ^{*2}	Intermittent ^{*1}		Max.	Min.	Flange Mtg.	Foot Mtg.
A10-FR07-12*	10.0(.610)	2(.122)	16(2320)	21(3050)	2.0(290)	1800	600	8.5(18.7)	10.7(23.6)
A16-*-R-07-*-K-32*	15.8(.964)	4(.244)	16(2320)	21(3050)	1.2(175)	1800	600	21(46.3)	23.2(51.2)
A22-*-R-07-*-K-32*	22.2(1.355)	6(.366)	16(2320)	16(2320)	1.2(175)	1800	600	21(46.3)	23.2(51.2)
A37-*-R-07-*-K-32*	36.9(2.25)	10(.610)	16(2320)	21(3050)	1.2(175)	1800	600	29(63.9)	33.3(73.4)
A56-*-R-07-*-K-32*	56.2(3.43)	12(.732)	16(2320)	21(3050)	1.2(175)	1800	600	36(79.4)	40.3(88.9)
A70-*-R07S-60*	70.0(4.27)	30(1.83)	25(3630)	25(3630)	2(290)	1800	600	60.3(133)	72.3(159)
A90-*-R07S-60*	91.0(5.55)	56(3.42)	25(3630)	25(3630)	2(290)	1800	600	77.5(171)	98(216)
A145-*-R07S-60*	145 (8.85)	83 (5.06)	25 (3630)	25 (3630)	2 (290)	1800	600	94 (207)	119 (262)

- ★1. Whenever setting pressure, make sure the full cut-off pressure never exceeds the maximum intermittent pressure.
- ★2. When operating the pump exceeding the rated pressure, operating conditions are restricted. Refer to page 6 for the details.

■ Model Number Designation

A16	-F	-R	-07	-S	-K	-32	*	
Series Number	Mounting	Direction of Rotation	Control Type	Port Position	Shaft Extension	Design Number	Design Std.	
A16 (15.8 cm ³ /rev)	F: Flange Mtg.	(Viewed from Shaft End)	07: Pilot Pressure Control Type Pressure Compensator	None: * ₂ Axial Port	K: Keyed Shaft	32	Refer to * ₄	
A22 (22.2 cm ³ /rev)						32		
A37 (36.9 cm ³ /rev)	L: Foot Mtg.					R: Clockwise (Normal) * ₁		32
A56 (56.2 cm ³ /rev)								32

A70	-F	R	07	S	-60	*	
Series Number	Mounting	Direction of Rotation	Control Type	Port Position	Design Number	Design Std.	
A10 (10.0 cm ³ /rev)	F: Flange Mtg. * ₃	(Viewed from Shaft End)	07: Pilot Pressure Control Type Pressure Compensator	—	12	Refer to * ₄	
A70 (70 cm ³ /rev)	F: Flange Mtg. L: Foot Mtg.			R: Clockwise (Normal) * ₁	S: Side Port		60
A90 (91.0 cm ³ /rev)							60
A145 (145 cm ³ /rev)							60

★1. Available to supply pump with anti-clockwise rotation. Consult Yuken for details. ★2. The axial port is not available to the N.American Design Standard of A37 and A56.

★3. When A10 pump is used as the foot Mtg., order the Mtg. Bracket kit shown below separately. Refer to page 17 for dimensions of the Mtg. bracket. ★4. Design Standards
None..... Japanese Standard "JIS"
80..... European Design Standard
90..... N. American Design Standard

Mtg. Bracket Kit Numbers	Approx. Mass kg (lbs.)
LP-1A-10	2.2 (4.9)

Note: The mounting bracket kit consists of a mounting bracket, 2 hex. bolts and 2 plain washer.

■ Performance Characteristics

For performance characteristics, refer to models of pressure compensator type on page 10 to 16.

■ Pipe Flange Kit

For pipe flange, refer to form of pressure compensator type on page 7.

Flange Mtg. : A10-FR07-12/1280/1290

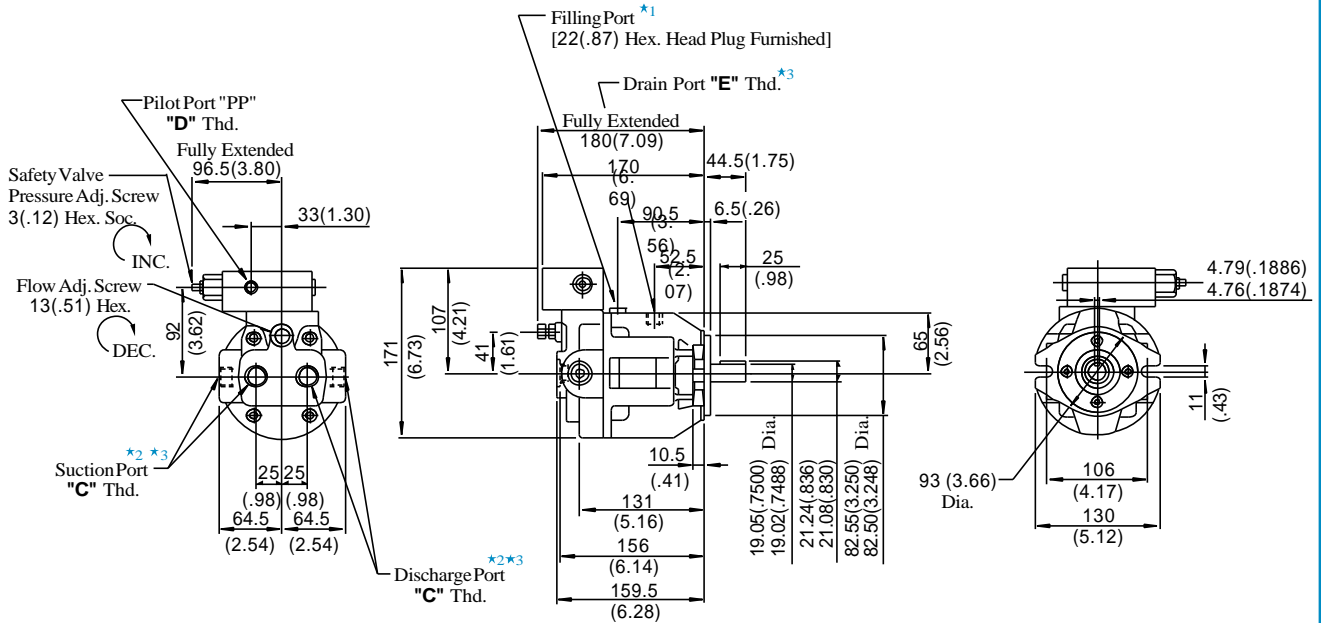

★ 1. Install the pump so that the "Filling Port" is at the top.

★ 2. Use either port of two suction and outlet ports at your option. Keep the remaining ports plugged.

★ 3. As the tightening torques of suction, discharge and drain port fittings, conform to the below.

Model Numbers	"C" Thd.	"D" Thd.	"E" Thd.
A10-FR07-12	Rc 1/2	Rc 1/4	Rc 3/8
A10-FR07-	1/2BSP.F	1/4BSP.Tr	3/8BSP.F
1280	1/2 NPT	1/4 NPT	3/8 NPT

Port	Tightening Torque
Suction Port Discharge Port	65 - 75 Nm (575 - 664 IN. lbs)
Drain Port	40 - 50 Nm (354 - 443 IN. lbs)

DIMENSIONS IN
MILLIMETRES (INCHES)

● Foot Mounting Type

Mounting bracket is common to that of pressure compensator model. Refer to page 17 for the dimensions of mounting bracket.

Installation Drawing

Axial Port Type

Flange Mtg. : A16-F-R-07-K-32/3280/3290
A22-F-R-07-K-32/3280/3290

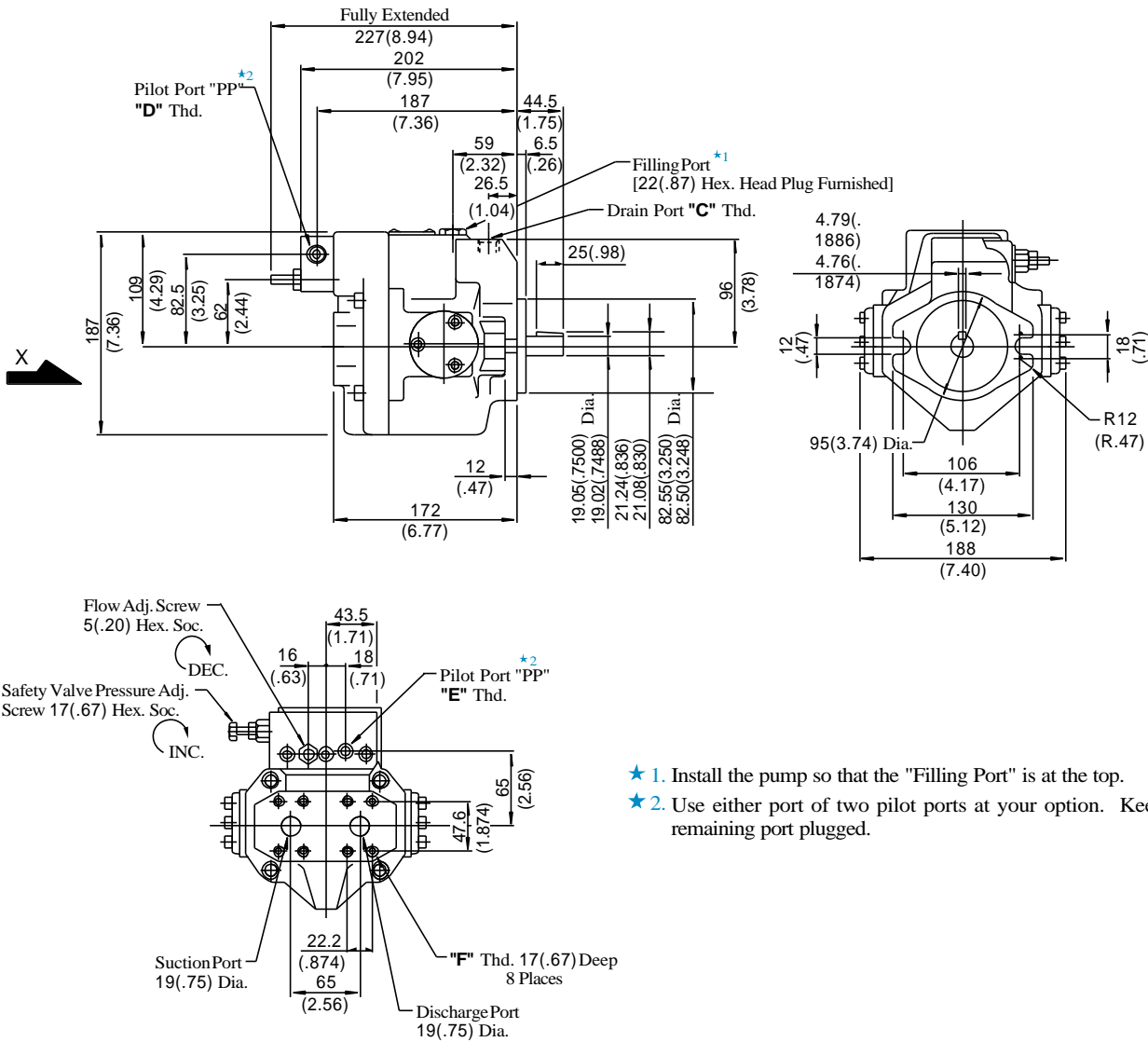

- ★ 1. Install the pump so that the "Filling Port" is at the top.
- ★ 2. Use either port of two pilot ports at your option. Keep the remaining port plugged.

View Arrow X

Model Numbers	"C" Thd.	"D" Thd.	"E" Thd.	"F" Thd.
A16/A22-F-R-07-K-32	Rc 3/8	Rc 3/8	Rc 1/4	M10
A16/A22-F-R-07-K-	3/8 BSP. F	3/8 BSP. F	1/4 BSP. Tr	
3280	3/8 NPT	3/8 NPT	1/4 NPT	3/8-16 UNC

DIMENSIONS IN
MILLIMETRES (INCHES)

● Side Port Type

Port mounting dimensions are the same as those of pressure compensator model. Refer to page 18 for port mounting dimensions.

● Foot Mounting Type

Mounting bracket is common to that of pressure compensator model. Refer to page 18 for the dimensions of mounting bracket.

Side Port Type

Flange Mtg. : A37-F-R-07-S-K-32/3280/3290

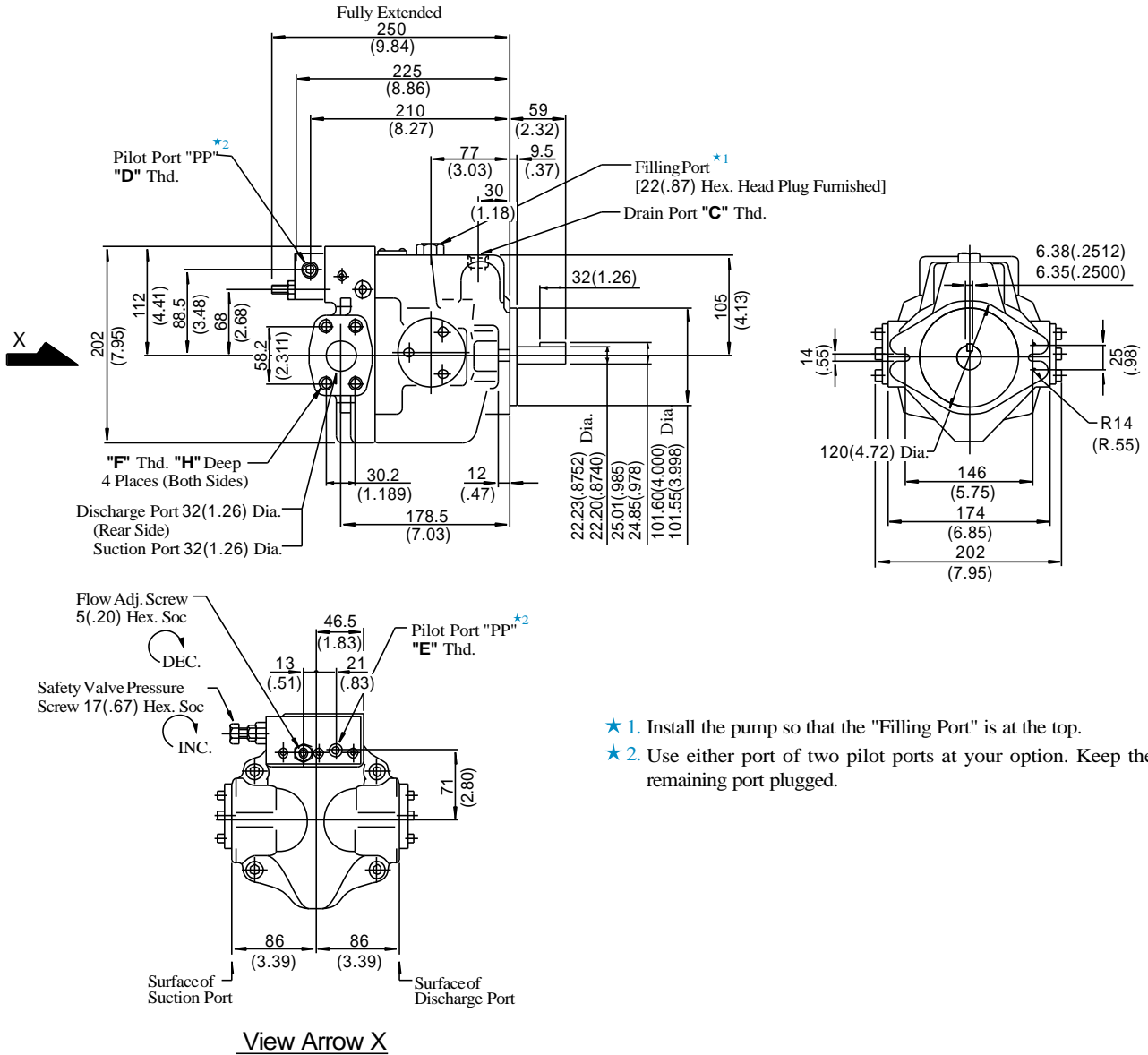

- ★ 1. Install the pump so that the "Filling Port" is at the top.
- ★ 2. Use either port of two pilot ports at your option. Keep the remaining port plugged.

View Arrow X

Model Numbers	"C" Thd.	"D" Thd.	"E" Thd.	"F" Thd.	"H" mm (IN.)
A37-F-R-07-S-K-32	Rc 1/2	Rc 3/8	Rc 1/4	M10	19 (.75)
A37-F-R-07-S-K-	1/2 BSP.F	3/8 BSP.F	1/4 BSP.Tr		
3280	1/2 NPT	3/8 NPT	1/4 NPT	7/16-14 UNC	20 (.79)

DIMENSIONS IN
MILLIMETRES (INCHES)

● Axial Port Type

Port mounting dimensions are the same as those of pressure compensator model. Refer to page 19 for port mounting dimensions.

Note: "Axial Port Type" is not available for N. American Design Standard.

● Foot Mounting Type

Mounting bracket is common to that of pressure compensator model. Refer to page 19 for the dimensions of mounting bracket.

Installation Drawing

Side Port Type

Flange Mtg. : A56-F-R-07-S-K-32/3280/3290

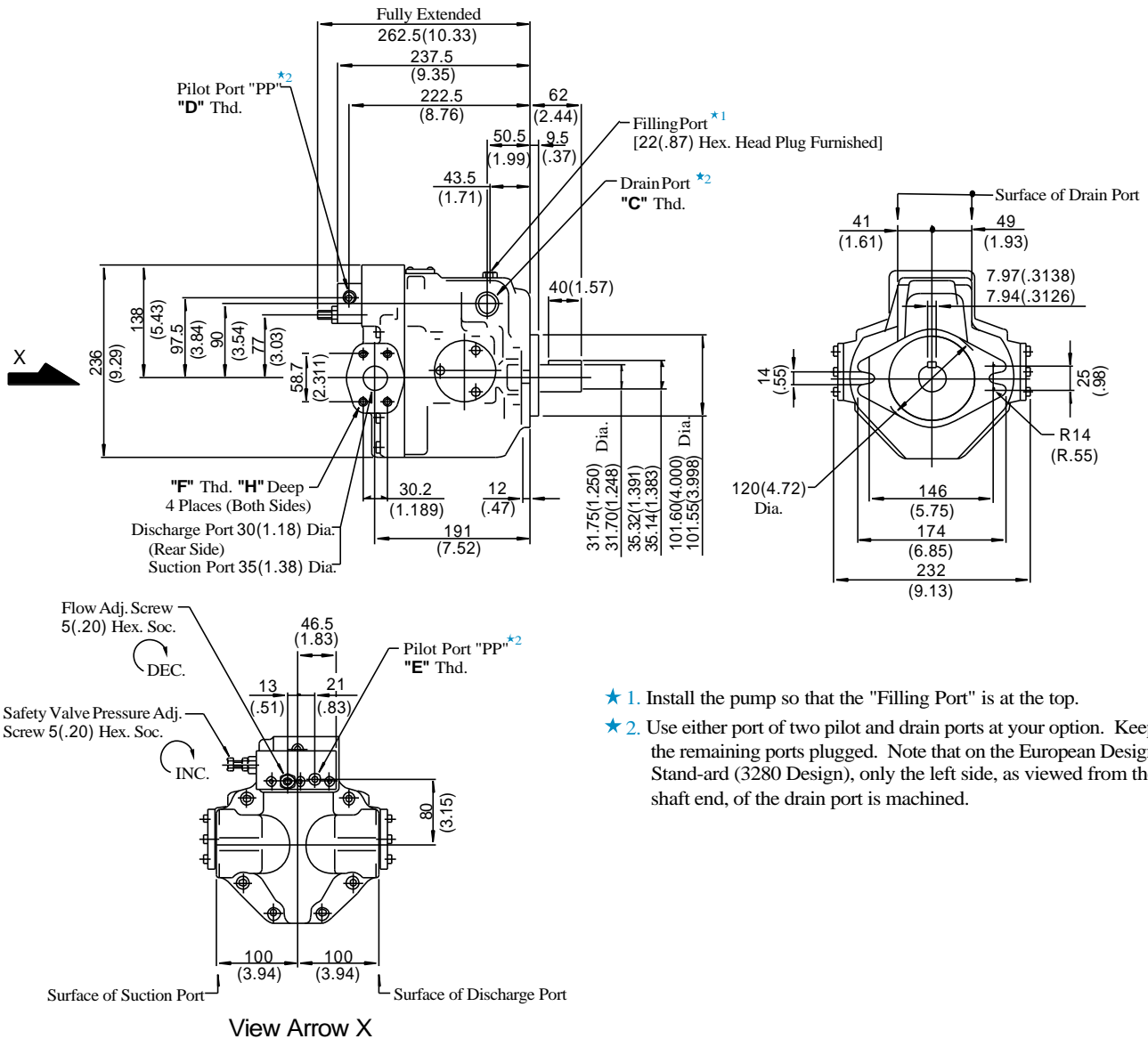

- ★ 1. Install the pump so that the "Filling Port" is at the top.
- ★ 2. Use either port of two pilot and drain ports at your option. Keep the remaining ports plugged. Note that on the European Design Standard (3280 Design), only the left side, as viewed from the shaft end, of the drain port is machined.

Model Numbers	"C" Thd.	"D" Thd.	"E" Thd.	"F" Thd.	"H" mm (IN.)
A56-F-R-07-S-K-32	Rc 3/4	Rc 3/8	Rc 1/4	M10	19 (.75)
A56-F-R-07-S-K-	3/4BSP.F	3/8BSP.F	1/4BSP.Tr		
3280	3/4 NPT	3/8 NPT	1/4 NPT	7/16-14 UNC	20 (.79)

DIMENSIONS IN
MILLIMETRES (INCHES)

● Axial Port Type

Port mounting dimensions are the same as those of pressure compensator model. Refer to page 20 for port mounting dimensions.

Note: "Axial Port Type" is not available for N. American Design Standard.

● Foot Mounting Type

Mounting bracket is common to that of pressure compensator model. Refer to page 20 for the dimensions of mounting bracket.

Flange Mtg. : A70-FR07S-60/6080/6090

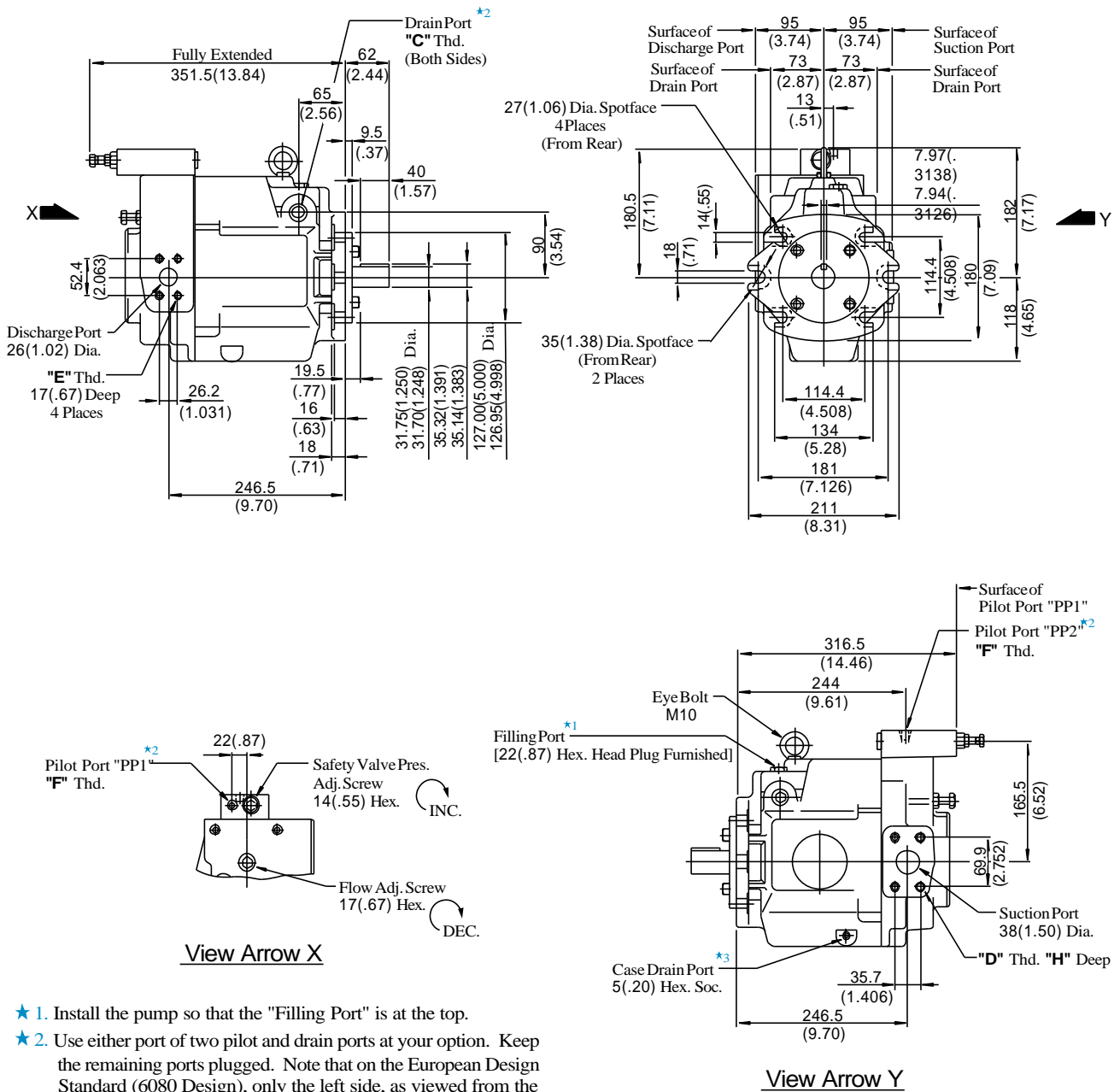

- ★ 1. Install the pump so that the "Filling Port" is at the top.
- ★ 2. Use either port of two pilot and drain ports at your option. Keep the remaining ports plugged. Note that on the European Design Standard (6080 Design), only the left side, as viewed from the shaft end, of the drain port is machined.
- ★ 3. Case drain port is available for use when draining hydraulic fluid from pump casing.

Model Numbers	"C" Thd.	"D" Thd.	"E" Thd.	"F" Thd.	"H" mm (IN.)
A70-FR07S-60	Rc 3/4	M12	M10	Rc 1/4	19 (.75)
A70-FR07S-6080	3/4BSP.F			1/4BSP.Tr	
A70-FR07S-6090	3/4 NPT	1/2-13 UNC	3/8-16 UNC	1/4 NPT	21 (.83)

DIMENSIONS IN
MILLIMETRES (INCHES)

● Foot Mounting Type

Mounting bracket is common to that of pressure compensator model. Refer to page 21 for the dimensions of mounting bracket.

Flange Mtg. : A90-FR07S-60/6080/6090

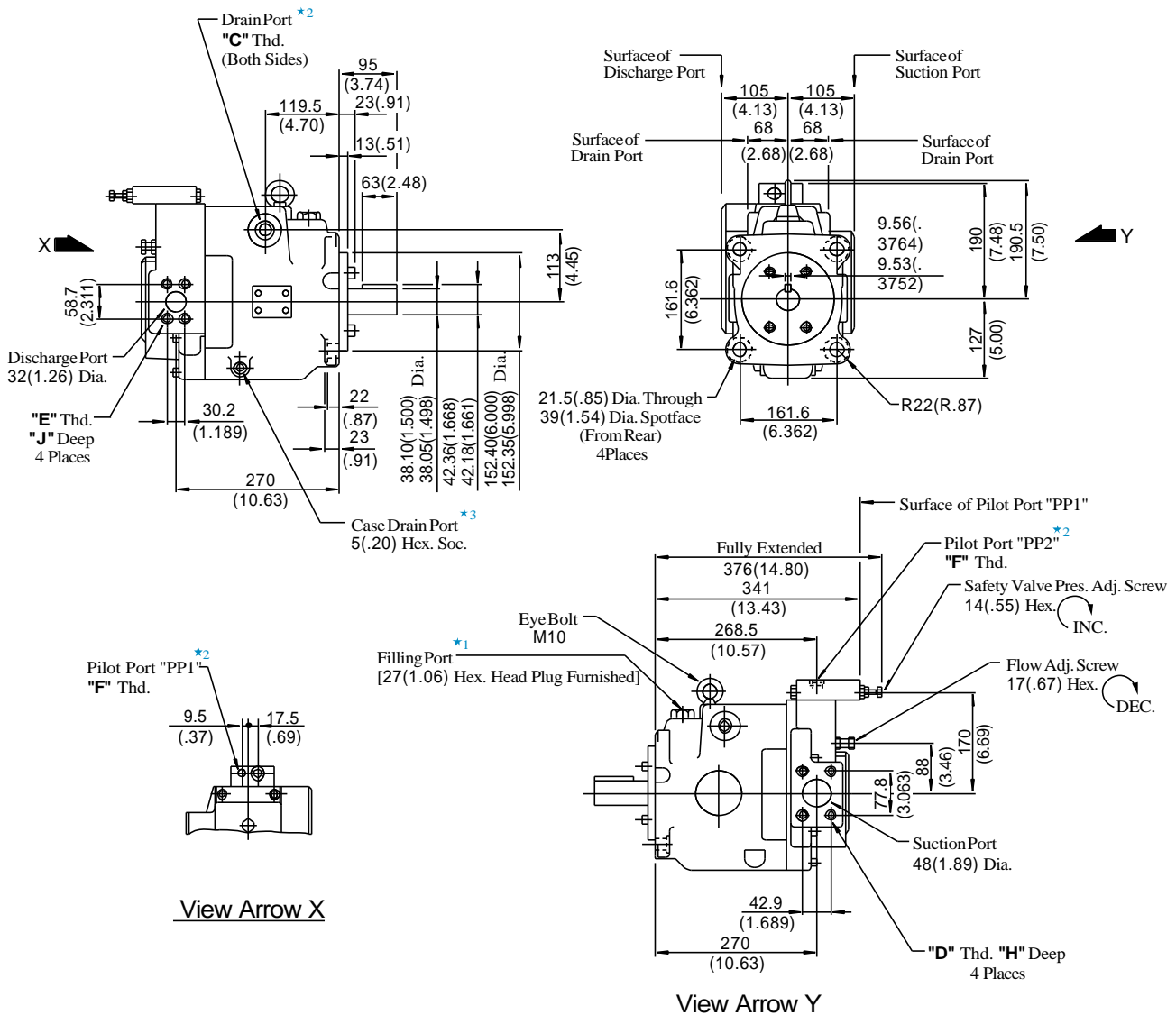

- ★ 1. Install the pump so that the "Filling Port" is at the top.
- ★ 2. Use either port of two pilot and drain ports at your option. Keep the remaining ports plugged. Note that on the European Design Standard (6080 Design), only the left side, as viewed from the shaft end, of the drain port is machined.
- ★ 3. Case drain port is available for use when draining hydraulic fluid from pump casing.

Model Numbers	"C" Thd.	"D" Thd.	"E" Thd.	"F" Thd.	H mm (IN.)	J mm (IN.)
A90-FR07S-60	Rc 3/4	M12	M10	Rc 1/4	19 (.75)	19 (.75)
A90-FR07S-6080	3/4 BSP.F			1/4 BSP. Tr		
A90-FR07S-6090	3/4 NPT	1/2-13 UNC	7/16-14 UNC	1/4 NPT	21 (.83)	20 (.79)

DIMENSIONS IN
MILLIMETRES (INCHES)

● Foot Mounting Type

Mounting bracket is common to that of pressure compensator model. Refer to page 22 for the dimensions of mounting bracket.

Flange Mtg. : A145-FR07S-60/6080/6090

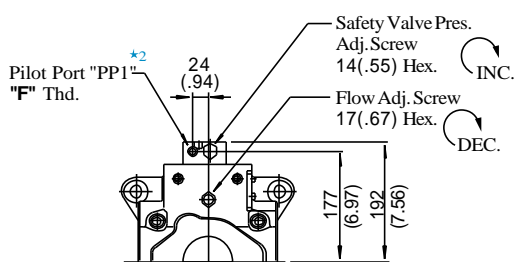
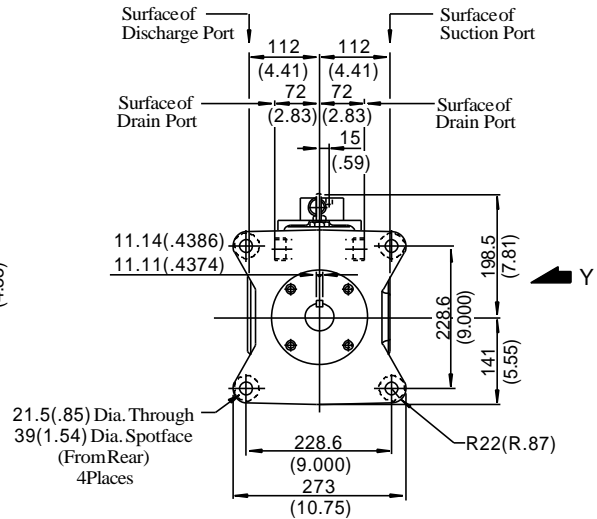
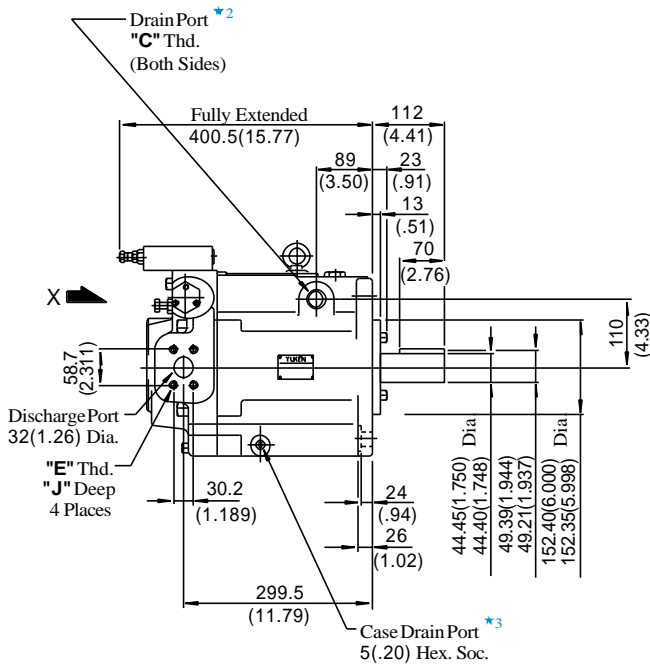

View Arrow X

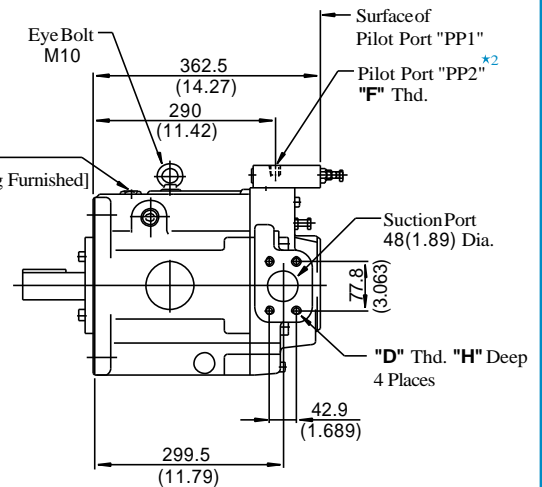

View Arrow Y

- ★ 1. Install the pump so that the "Filling Port" is at the top.
- ★ 2. Use either port of two pilot and drain ports at your option. Keep the remaining ports plugged. Note that on the European Design Standard (6080 Design), only the left side, as viewed from the shaft end, of the drain port is machined.
- ★ 3. Case drain port is available for use when draining hydraulic fluid from pump casing.

Model Numbers	"C" Thd.	"D" Thd.	"E" Thd.	"F" Thd.	H mm (IN.)	J mm (IN.)
A145-FR07S-60	Rc 3/4	M12	M10	Rc 1/4	19 (.75)	19 (.75)
A145-FR07S-6080	3/4BSP.F			1/4BSP. Tr		
A145-FR07S-6090	3/4 NPT	1/2-13 UNC	7/16-14 UNC	1/4 NPT	21 (.83)	20 (.79)

DIMENSIONS IN
MILLIMETRES (INCHES)

● Foot Mounting Type

Mounting bracket is common to that of pressure compensator model. Refer to page 23 for the dimensions of mounting bracket.