



UNLOADING RELIEF VALVES

**BU CG-06/10 (3/4, 1-1/4)
Sub-plate Mounting**

**PRESSURE
CONTROLS**

Specifications / Model Number Designation

Up to 21 MPa (3050 PSI), 250 L/min (66 U.S.GPM)

These valves are used to operate the pumps with minimum load in accumulator circuits or in high-low pump circuits.

In accumulator circuits, when the system pressure reaches to a cut out pressure (adjusted maximum), the valve acts to divert the pump delivery to the reservoir at low pressure, thus the pump is unloaded automatically. When the accumulator pressure drops to the cut in pressure (refer to characteristic chart on page 5), the valve directs the pump delivery to the accumulator and hydraulic system.

An integral check valve prevents reverse flow through the valve from the accumulator.

In high-low pump circuits, the valve acts to unload the large volume pump with the same manner as described above during load operation of the small volume pump.

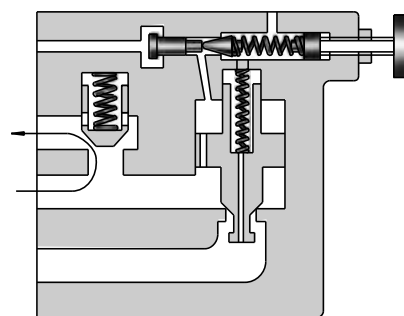

Specifications

Model Numbers	Max. Operating Pres. MPa (PSI)	Max. Flow L/min (U.S.GPM)	Approx. Mass kg(lbs.)
BU CG-06-* *-30/3080/3090	21 (3050)	125 (33)	12 (26.5)
BU CG-10-* *-25/2580/2590		250 (66)	21.5 (47.4)

Graphic Symbol

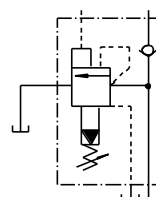

Model Number Designation

F-	BUC	G	-06	-B	V	-30	*
Special Seals	Series Number	Type of Mounting	Valve Size	Cut-out Pres. Adj. Range MPa (PSI)	High Venting* Pres. Feature	Design Number	Design Standards
F: Special Seals for Phosphate Ester Type Fluids (Omit if not required)	BUC: Unloading Relief Valve	G: Sub-plate Mounting	06 10	B: 2.5-7.0 (360-1020) C: 3.5-14 (510-2030) H: 7.0-21 (1020-3050)	V: For High Venting Pressure Feature (Omit if not required)	30 25	N Japanese Std. "JIS" 80: European Design Std. 90: N. American Design Std.

* Use the high-venting-pressure type to reduce the shift time from unloading to onloading.

Hydraulic Fluids

Fluid Types

Any type of hydraulic fluids listed in the table below can be used.

Petroleum base oils	Use fluids equivalent to ISO VG32 or VG46.
Synthetic fluids	Use phosphate ester or polyol ester fluid. When phosphate ester fluid is used, prefix "F-" to the model number because the special seals (fluororubber) are required to be used.
Water containing fluids	Use water-glycol fluid.

Note: For use with hydraulic fluids other than those listed above, please consult your Yuken representatives in advance.

Recommended Viscosity and Oil Temperatures

Recommended Viscosity and Oil Temperatures

Viscosity ranging between 15 - 400 mm²/s (77 - 1800 SSU).

Oil temperatures between -15/+70°C (5 - 158 F).

Use hydraulic fluids which satisfy the recommended viscosity and oil temperatures given above.

Control of Contamination

Due caution must be paid to maintaining control over contamination of the hydraulic fluids which may otherwise lead to breakdowns and shorten the life of the valves. Please maintain the degree of contamination within NAS 1638-Grade 12. Use 25 µm or finer line filter.

Instructions

- To adjust the pressure, loosen the lock nut and turn the pressure adjustment handle slowly clockwise for higher pressures or anti-clockwise for lower pressures. After adjustments, do not forget to tighten the lock nut.
- Take care not to neglect connecting the drain pipe to the tank; otherwise not only will the valve fail to operate properly but also the line pressure will rise infinitely. Extend the end of the drain pipe into fluid.
- Limit the pressure drop between the valve and the accumulator in an accumulator circuit below 10% of the cut-out pressure.
- Limit the drain port back pressure below 2% of the cut-out pressure.

Attachment

Mounting Bolts

Valve Model Numbers	Socket Head Cap Screw	
	Japanese Std. "JIS" and European Design Std.	N. American Design Std.
BUCG-06	M16 × 55Lg. (2 pcs.)	5/8-11 UNC × 2-1/4 Lg. (2 pcs.)
	M16 × 110Lg. (2 pcs.)	5/8-11 UNC × 4-1/2 Lg. (2 pcs.)
	M16 × 130Lg. (2 pcs.)	5/8-11 UNC × 5 Lg. (2 pcs.)
BUCG-10	M20 × 70Lg. (2 pcs.)	3/4-10 UNC × 2-3/4 Lg. (2 pcs.)
	M20 × 160Lg. (4 pcs.)	3/4-10 UNC × 6-1/2 Lg. (4 pcs.)

Sub-plate

Valve Model Numbers	Japanese Standard "JIS"		European Design Standard		N. American Design Standard		Approx. Mass kg (lbs.)
	Sub-plate Model Numbers	Thread Size	Sub-plate Model Numbers	Thread Size	Sub-plate Model Numbers	Thread Size	
BUCG-06	BUCGM-06-20	Rc 3/4	BUCGM-06-2080	3/4 BSP.F	BUCGM-06-2090	3/4 NPT	4.4 (9.7)
BUCG-10	BUCGM-10-20	Rc 1-1/4	BUCGM-10-2080	1-1/4 BSP.F	BUCGM-10-2090	1-1/4 NPT	7.2 (15.9)

- Sub-plates are available. Specify the sub-plate model number from the table above. When sub-plates are not used, the mounting surface should have a good machined finish.

