



PRESSURE REDUCING AND RELIEVING VALVES

**RBG-03 / 06 (3/8 , 3/4)
Sub-plate Mounting**

**PRESSURE
CONTROLS**

Specifications / Model Number Designation / Others

Up to 25 MPa (3630 PSI), 125 L/min (33 U.S.GPM)

Pressure reducing and relieving valves are composite pressure control valves having pressure reducing and counterbalancing functions developed for hydraulic balancing circuits.

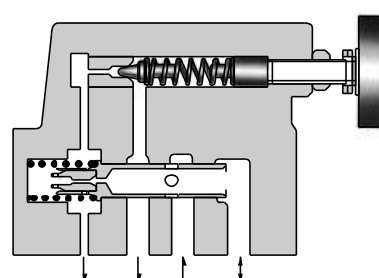

Specifications

Model Numbers	Max. Operating Pressure MPa (PSI)	Pres. Adj. Range MPa (PSI)	Max. Flow L/min (U.S.GPM)	Relieving Flow L/min (U.S.GPM)	Drain Flow L/min (U.S.GPM)	Approx. Mass kg (lbs.)
RBG-03-* -10*	14 (2030)	0.6-13.5 (90-1960)	50 (13.2)	50 (13.2)	0.6-1 (.16-.26)	4.2 (9.3)
RBG-06-* -10*	25 (3630)	0.8-24.5 (120-3550)	125 (33)	125 (33)	1.5-2 (.40-.53)	11 (24.3)

Model Number Designation

F-	RB	G	-03	-R	-10	*
Special Seals	Series Number	Type of Mounting	Valve Size	Drain Type	Design Number	Design Standards
F: Special Seals for Phosphate Ester Type Fluids (Omit if not required)	RB: Pressure Reducing and Relieving Valves	G: Sub-plate Mounting	03 06	None: Internal Drain R: External Drain	10 10	Refer to ★

★ Design Standards:None..... Japanese Standard "JIS"
80..... European Design Standard
90..... N. American Design Standard

Graphic Symbols

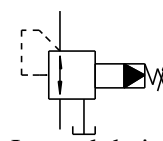

Internal drain

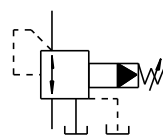

External drain

Attachment

Mounting Bolts

Valve Model Numbers	Socket Head Cap Screw (4 pcs.)	
	Japanese Standard "JIS" European Design Standard	N. American Design Standard
RBG-03	M10 × 65 Lg.	3/8-16 UNC × 2-1/2 Lg.
RBG-06	M10 × 70 Lg.	3/8-16 UNC × 2-3/4 Lg.

Sub-plate

Valve Model Numbers	Piping Size	Japanese Standard "JIS"		European Design Standard		N. American Design Standard		Approx. Mass kg (lbs.)
		Sub-plate Model Numbers	Thread Size	Sub-plate Model Numbers	Thread Size	Sub-plate Model Numbers	Thread Size	
RBG-03	3/8	RBGM-03-10	Rc 3/8	RBGM-03-1080	3/8BSP.F	RBGM-03-1090	3/8NPT	1.6 (3.5)
	1/2	RBGM-03X-10	Rc 1/2	RBGM-03X-1080	1/2BSP.F	RBGM-03X-1090	1/2NPT	
RBG-06	3/4	RBGM-06-10	Rc 3/4	RBGM-06-1080	3/4BSP.F	RBGM-06-1090	3/4NPT	4.8 (10.6)
	1	RBGM-06X-10	Rc 1	RBGM-06X-1080	1 BSP.F	RBGM-06X-1090	1 NPT	

• Sub-plates are available. Specify the sub-plate model number from the table above. When sub-plates are not used, the mounting surface should have a good machined finish.

Hydraulic Fluids

Fluid Types

Any type of hydraulic fluids listed in the table below can be used.

Petroleum base oils	Use fluids equivalent to ISO VG32 or VG46.
Synthetic fluids	Use phosphate ester or polyol ester fluid. When phosphate ester fluid is used, prefix "F-" to the model number because the special seals (fluororubber) are required to be used.
Water containing fluids	Use water-glycol fluid.

Note: For use with hydraulic fluids other than those listed above, please consult your Yuken representatives in advance.

Recommended Viscosity and Oil Temperatures

Viscosity ranging between 15 - 400 mm²/s (77 - 1800 SSU).

Oil temperatures between -15/+70℃ (5 - 158℉).

Use hydraulic fluids which satisfy the recommended viscosity and oil temperatures given above.

Control of Contamination

Due caution must be paid to maintaining control over contamination of the hydraulic fluids which may otherwise lead to breakdowns and shorten the life of the valves. Please maintain the degree of contamination with-in NAS 1638-Grade 12. Use 25 μm or finer line filter.

Instructions

- To use remote control relief valve in the venting circuit, see the Catalogue No. Pub. EC-0201. If the internal volume of the vent line is too large, chattering is likely to occur. Thus, as far as possible reduce the inside Dia and the length of the pipe.
- To adjust the pressure, loosen the lock nut and turn the pressure adjustment handle slowly clockwise for higher pressures and anti-clockwise for lower pressures. After adjustments, do not forget to tighten the lock nut.
- Pressure is limited by collars fitted. If a working pressure cannot be attained, remove some collars. One collar is equivalent to 10 MPa (1450 PSI).
- Connect the tank pipe not to any other line but directly to the tank.

Features and applications of pressure reducing and relieving valves

A conventional circuit composed of a pressure reducing valve, a relief valve (for counterbalance) and a check valve can be replaced with one pressure reducing and relieving valve. This enables balancing pressures to be adjusted easily and permits the circuit to be greatly simplified, resulting in a lower cost. If the load is changed, the balancing pressure can be reset easily only by operating the pressure adjustment handle. Pressure reducing and relieving valves can be applied to hydraulic balance circuits such as balance mechanisms of machining centers.

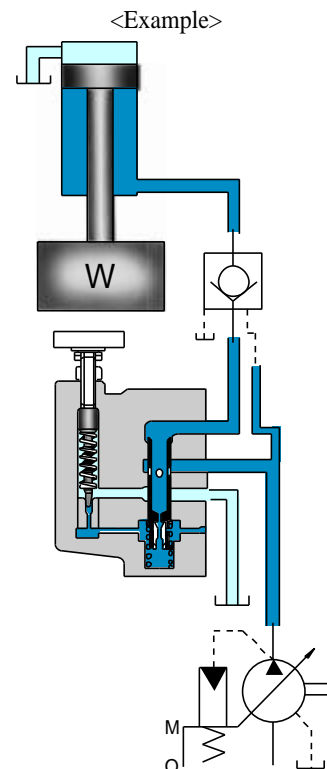

RBG-03-* -10/1080/1090

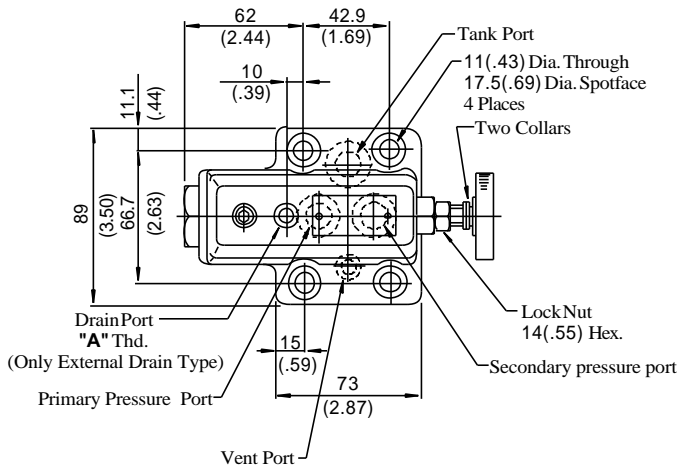

Model Numbers	"A" Thd.
RBG-03-10	Rc 1/4
RBG-03-1080	1/4 BSP.F
RBG-03-1090	1/4 NPT

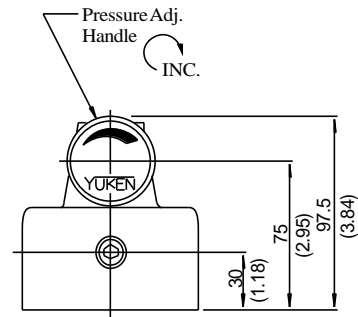
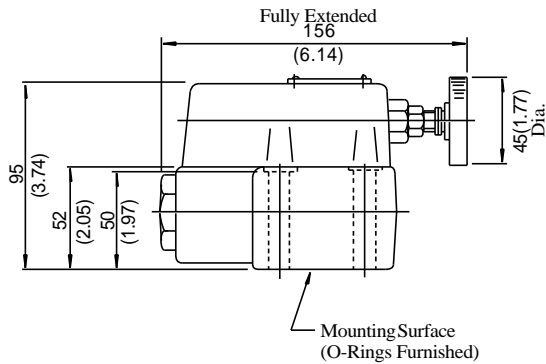

DIMENSIONS IN
MILLIMETRES (INCHES)

Sub-plate : RBGM₀₃⁰³X -10/1080/1090

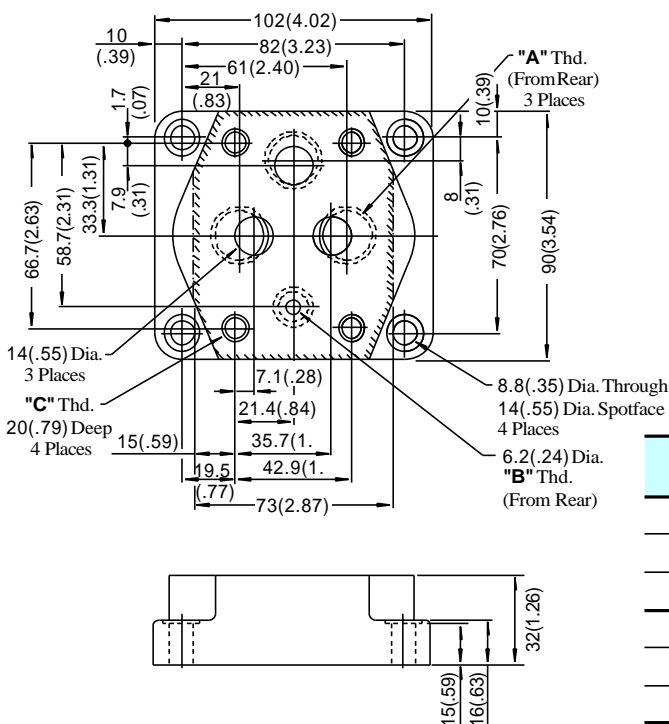

Sub-plate Model Numbers	"A" Thd.	"B" Thd.	"C" Thd.
RBGM-03-10	Rc 3/8	Rc 1/4	M10
RBGM-03-1080	3/8 BSP.F	1/4 BSP.F	
RBGM-03-1090	3/8 NPT	1/4 NPT	3/8-16 UNC
RBGM-03X-10	Rc 1/2	Rc 1/4	M10
RBGM-03X-1080	1/2 BSP.F	1/4 BSP.F	
RBGM-03X-1090	1/2 NPT	1/4 NPT	3/8-16 UNC

RBG-06-* -10/1080/1090

Model Numbers	"A" Thd.
RBG-06-10	Rc 3/8
RBG-06-1080	3/8BSP.F
RBG-06-1090	3/8 NPT

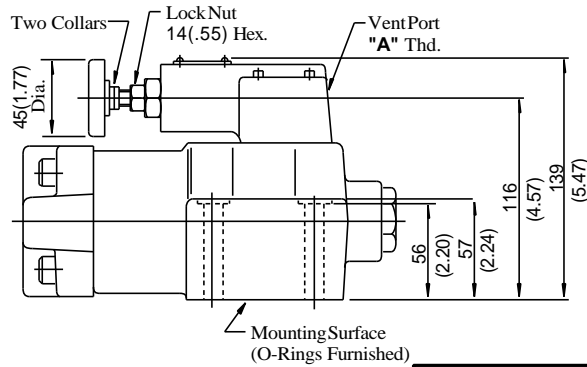
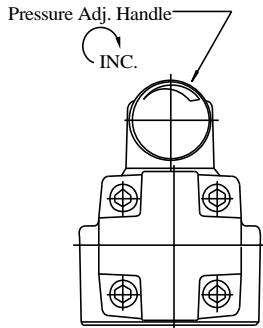
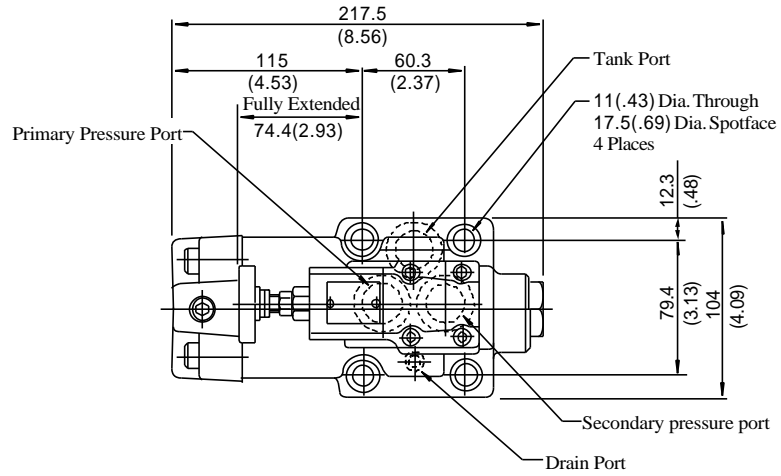

**DIMENSIONS IN
MILLIMETRES (INCHES)**

Sub-plate : RBGM⁰⁶_{06X} -10/1080/1090

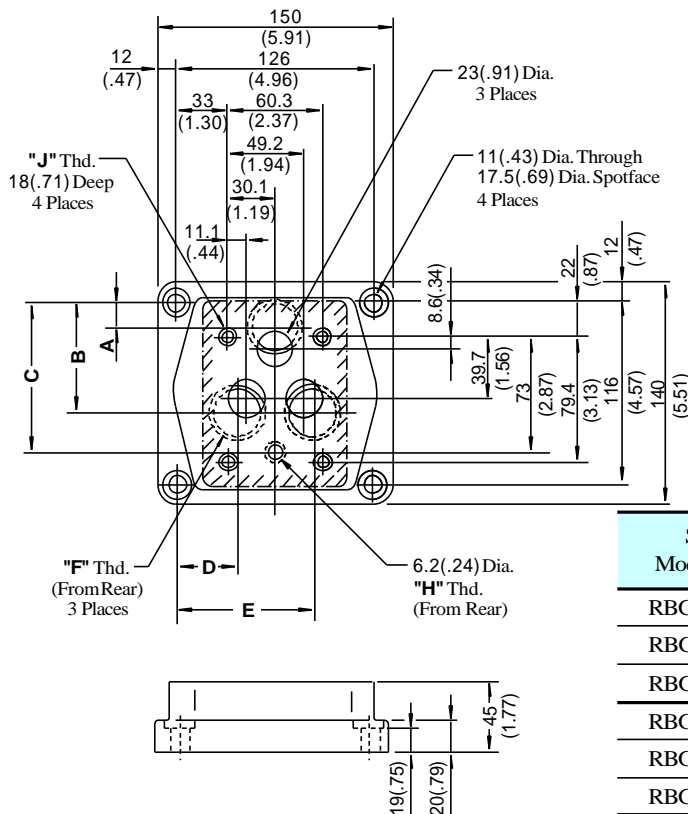

Model Numbers	Dimensions mm (Inches)				
	A	B	C	D	E
RBGM-06	20.7 (.81)	65.7 (2.59)	95 (3.74)	37.1 (1.46)	89.1 (3.51)
RBGM-06X	20.4 (0.80)	69.7 (2.74)	98.4 (3.87)	32.5 (1.28)	93.8 (3.69)

Sub-plate Model Numbers	Thread Size		
	"F" Thd.	"H" Thd.	"J" Thd.
RBGM-06-10	Rc 3/4	Rc 1/4	M10
RBGM-06-1080	3/4BSP.F	1/4BSP.F	
RBGM-06-1090	3/4 NPT	1/4 NPT	3/8-16 UNC
RBGM-06X-10	Rc 1	Rc 1/4	M10
RBGM-06X-1080	1 BSP.F	1/4BSP.F	
RBGM-06X-1090	1 NPT	1/4 NPT	3/8-16 UNC

Hydraulic Fluid: Viscosity 35 mm²/s (164 SSU) , Specific Gravity 0.850

Nominal Override Characteristics

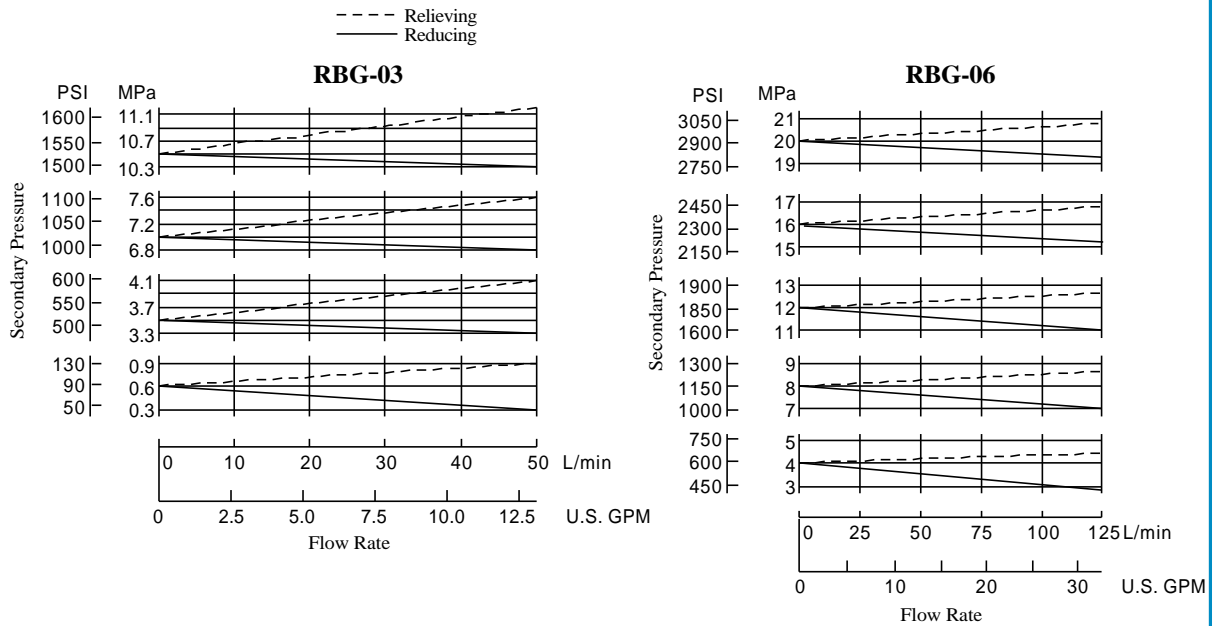

Min. Adj. Pressure & Vent Pressure

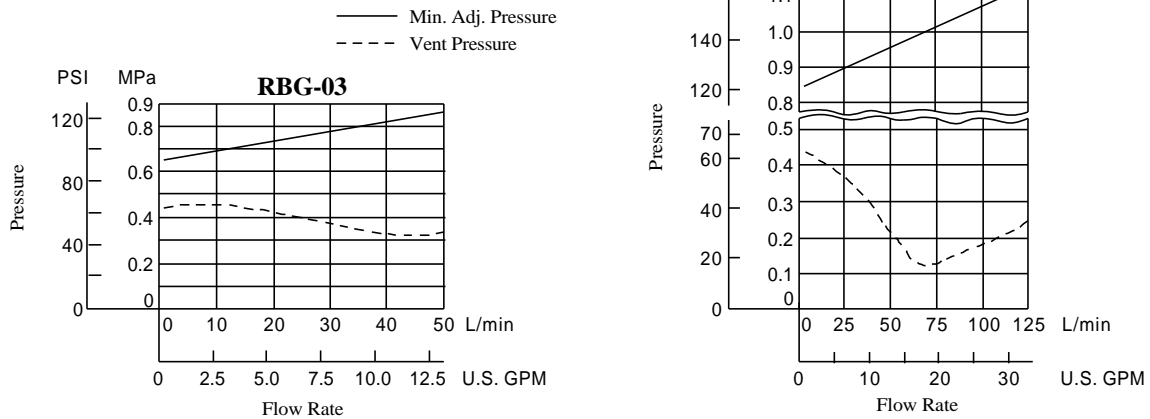

Pressure Drop

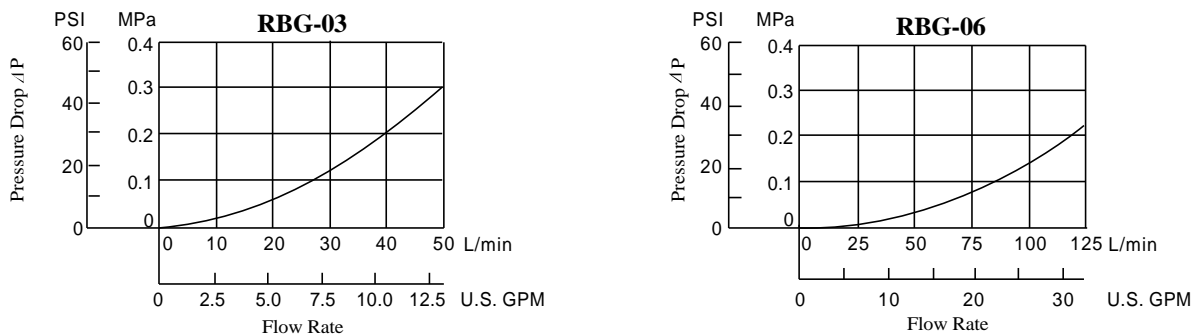

● For any other viscosity, multiply the factors in the table below.

Viscosity	mm ² /s	15	20	30	40	50	60	70	80	90	100
		SSU	77	98	141	186	232	278	324	371	417
Factor		0.81	0.87	0.96	1.03	1.09	1.14	1.19	1.23	1.27	1.30

● For any others specific gravity (G'), the pressure drop (P') may be obtained from the formula below.

$$\Delta P' = \Delta P (G'/0.850)$$

