

1/8, Relief Valves

For "P" Line: MBP-01-* -30/3090
 For "A" Line: MBA-01-* -30/3090
 For "B" Line: MBB-01-* -30/3090

Specifications / Others

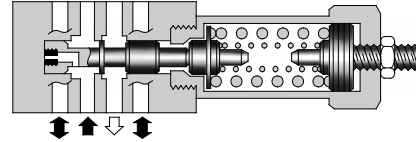

Specifications

Model Numbers	Max. Operating Pressure MPa (PSI)	Max. Flow L/min (U.S.GPM)
MBP-01-* -30/3090 MBA-01-* -30/3090 MBB-01-* -30/3090	21 (3050)	35 (9.25)

Model Number Designation

F-	MBP	-01	-C	-30	*
Special Seals	Series Number	Valve Size	Pres. Adj. Range MPa (PSI)	Design Number	Design Standard
F: Special Seals for Phosphate Ester Type Fluids (Omit if not required)	MBP: Relief Valve for P-Line MBA: Relief Valve for A-Line MBB: Relief Valve for B-Line	01	C: *-14 ^{★1} (* -2030) H: 7-21 (1020-3050)	30	Refer to ^{★2}

★ 1. See the "Minimum Adjustment Pressure" of the next page for the item marked *.

★ 2. Design Standards: None Japanese Standard "JIS" and European Design Standard
 90 N. American Design Standard

Instructions

- The minimum adjustment pressure equals the value obtained from the minimum adjustment pressure characteristics plus the tank line back pressure of the next page. This back pressure should include the value of the T-line pressure drop characteristics of the valves stacked to the base plate side of the modular valve.
- To make pressure adjustment, loosen the lock nut and turn the pressure adjustment screw clockwise or anti-clockwise. For an increase of pressure, turn the screw clockwise. Be sure to re-tighten the lock nut firmly after making adjustment to the pressure.
- In case of a small flow, the setting pressure may become unstable. To avoid this, refer to the minimum flow characteristic curve of the next page and use the valve within a range as shown with .

Graphic Symbols

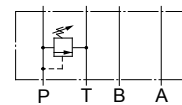

MBP-01

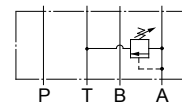

MBA-01

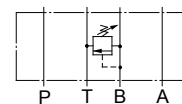

MBB-01

Hydraulic Fluid: Viscosity 35 mm²/s (164 SSU), Specific Gravity 0.850

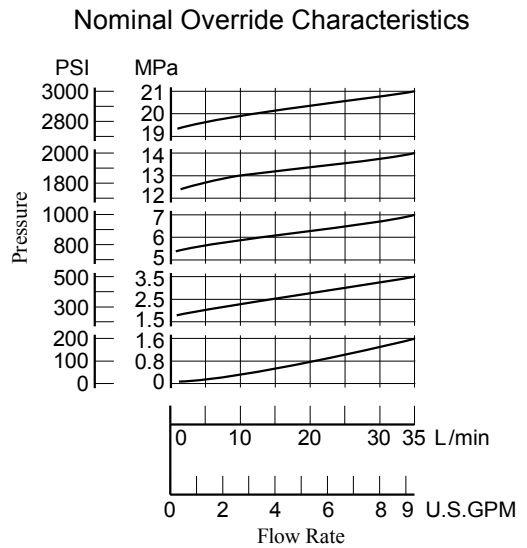
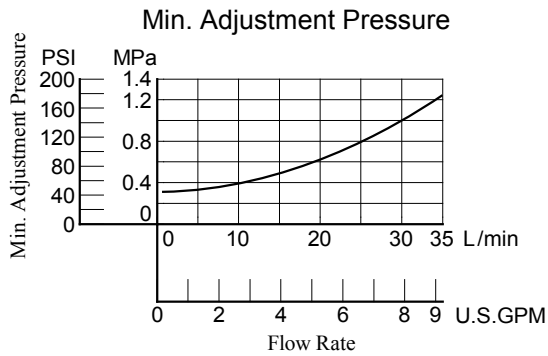
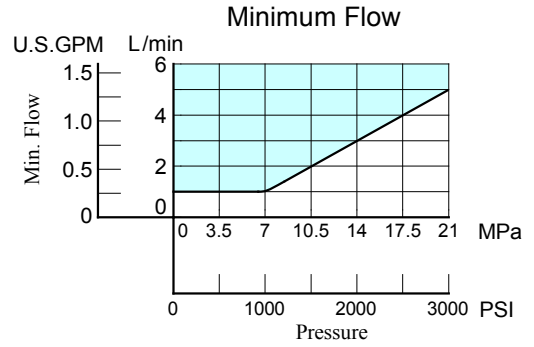
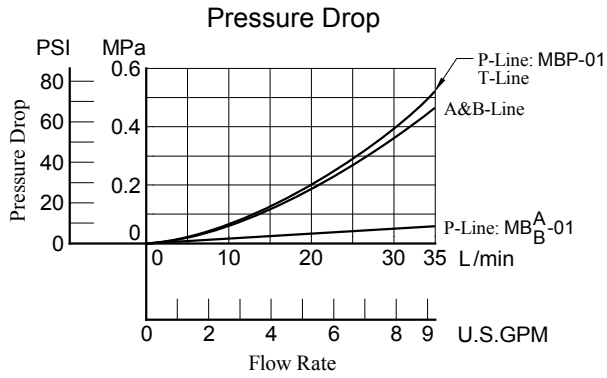

MBP-01-*30/3090
MBB-01-*30/3090

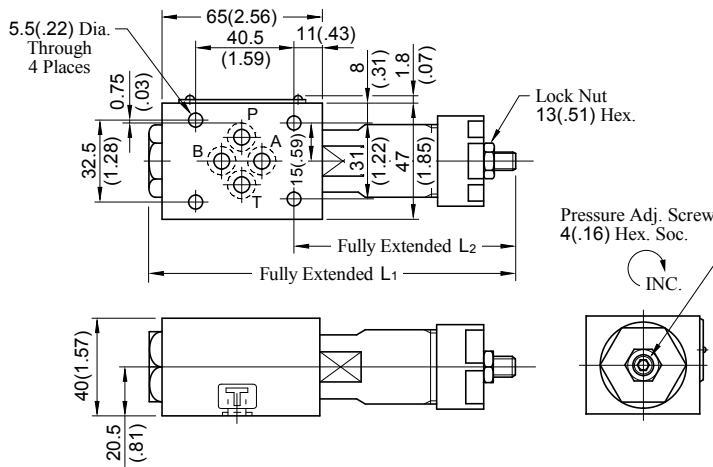

Model No.	L ₁	L ₂
MB*-01-C	151 (5.94)	92 (3.62)
MB*-01-H	166.5 (6.56)	107.5 (4.23)

Approx. Mass..... 1.1 kg (2.4 lbs.)

**DIMENSIONS IN
MILLIMETRES (INCHES)**

MBA-01-*30/3090

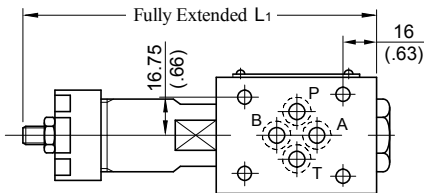

Approx. Mass..... 1.1 kg (2.4 lbs.)

• For other dimensions, refer to above (MBP-01) drawing.

■ Spare Parts List

MBP-01-*30/3090

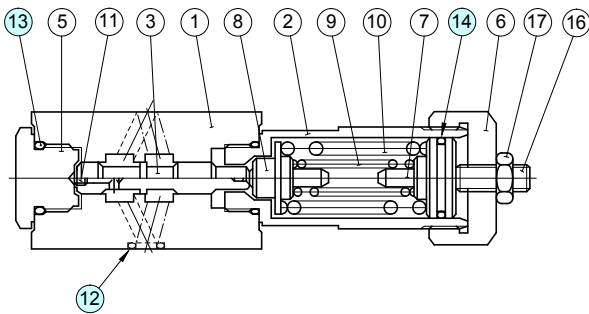

MBA-01-*30/3090

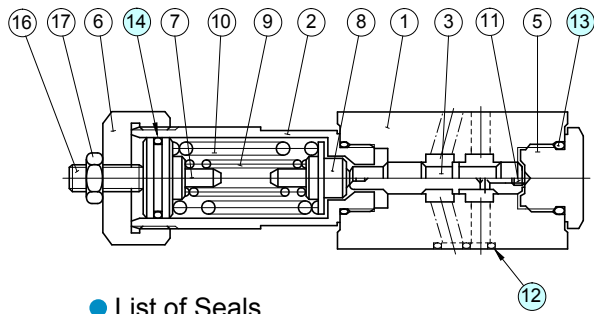

MBB-01-*30/3090

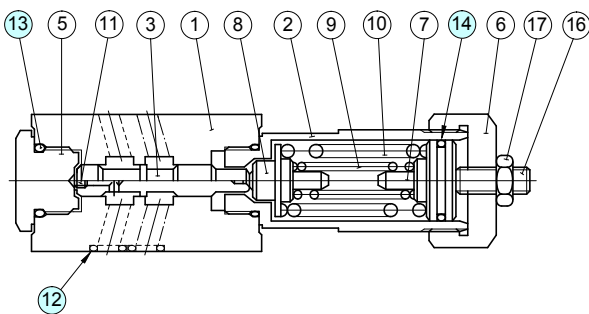

● List of Seals

Item	Name of Parts	Part Numbers	Qty.
12	O-Ring	SO-NB-P9	4
13	O-Ring	SO-NB-P18	2
14	O-Ring	SO-NA-P20	1

Note: When ordering seals, please specify the seal kit number from the table below.

● List of Seal Kit

Model No.	Seal kit No.
MBP-01	KS-MBP-01-30
MBA-01	
MBB-01	

⚠ CAUTION

When making replacement of seals, please do it carefully after reading through the relevant instructions in the Operator's Manual.